

**DAIKIN**

# INSTALLATION MANUAL



## MODELS

FTYN20LV1B  
FTYN25LV1B  
FTYN35LV1B  
FTYN50LV1B  
FTYN60LV1B

RYN20LV1B  
RYN25LV1B  
RYN35LV1B  
RYN50LV1B  
RYN60LV1B

Installation Manual  
Wall Mounted Split Type Air  
Conditioner

English

Manuel d'installation  
Climatiseurs Split System Montage  
Mural

Français

Installationshandbuch  
Doppelfunktions-Klimagerät and  
Montiert

Deutsch

Manuale Di Installazione  
Condizionatore Split A Parete

Italiano

Manual de instalación  
Equipo de air Acondicionado de  
tipo Dividido de Montaje Mural

Español

Руководство По Установке  
Настенный Кондиционер  
Раздельного типа

Русский

Kurulum Kılavuzu  
Duvara Monteli Split Tipi Klima

Türkçe

**EAC**

IM-5WMJ-1211(5)-DAIKIN  
Part No.: R08019037260E



## OUTLINE AND DIMENSIONS

### Indoor Unit (FTYN)

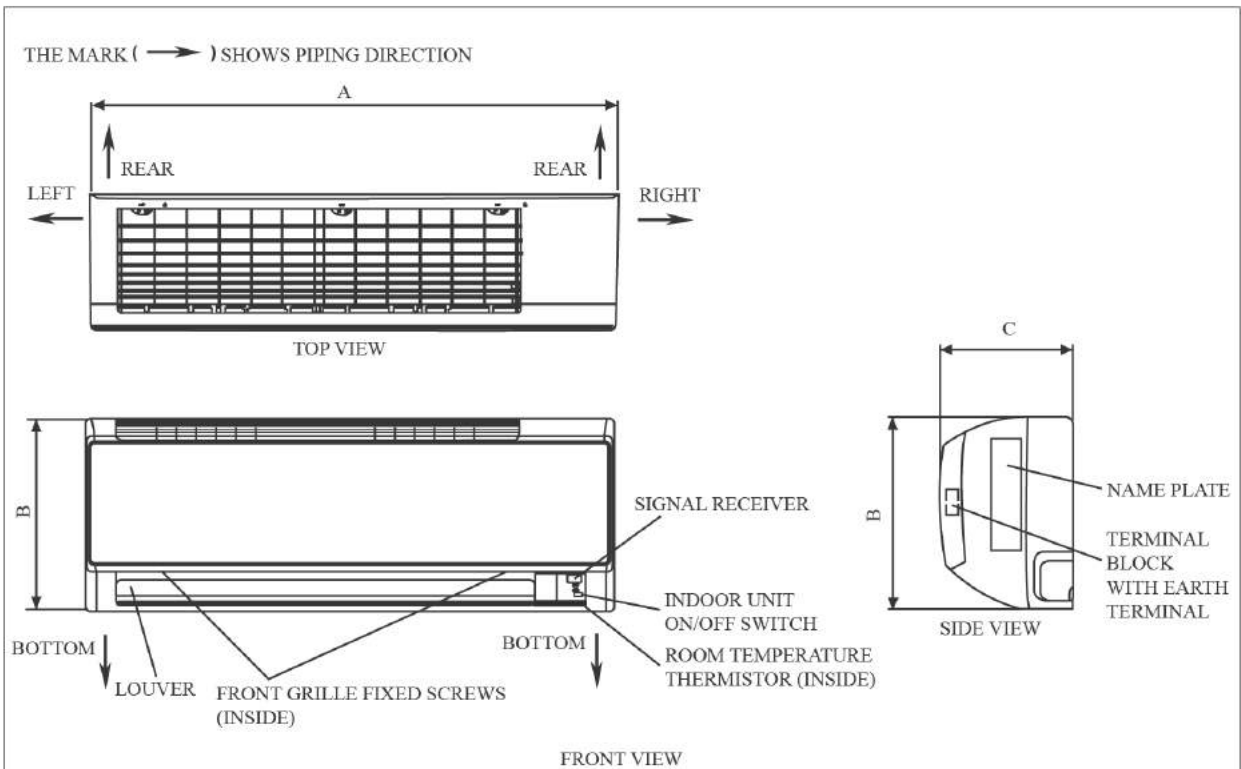

NOTE: PLEASE BASED ON ACTUAL INSTALLATION PLATE DESIGN IN THE UNIT FOR INSTALLATION PLATE 20/25/35 DIMENSION REFERENCE AT PAGE 1&2.

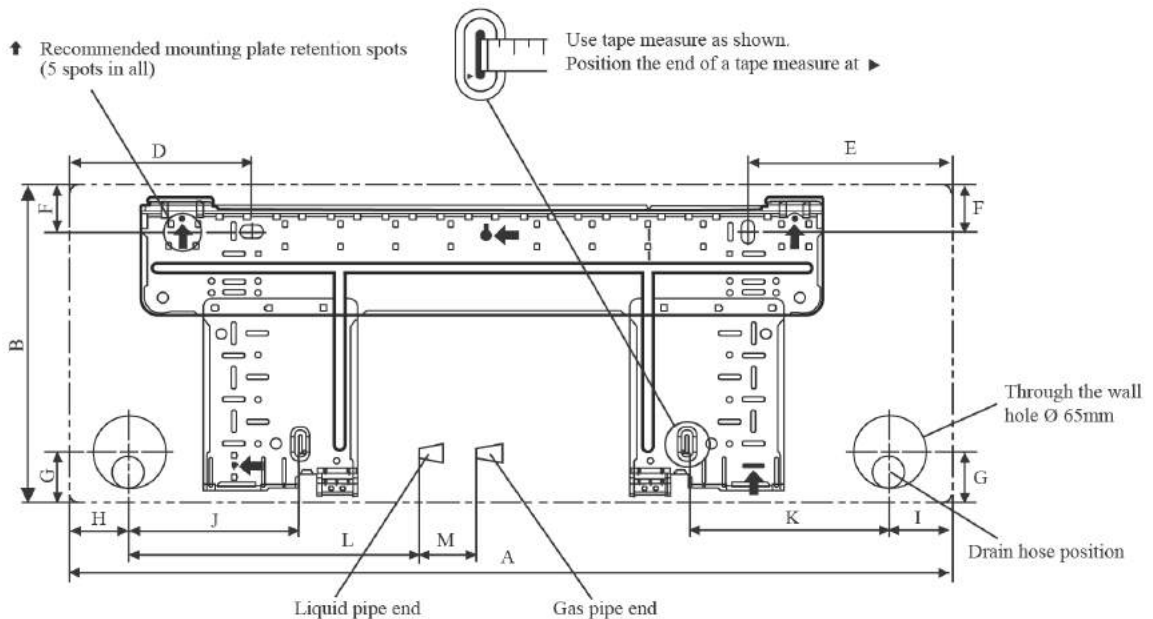

INSTALLATION PLATE 20/25/35

Dimension Model	A	B	C	D	E	F	G	H	I	J	K	L	M
20/25/35	800	288	206	166	184	42	46	55	56	154	182	263	52

All dimensions are in mm

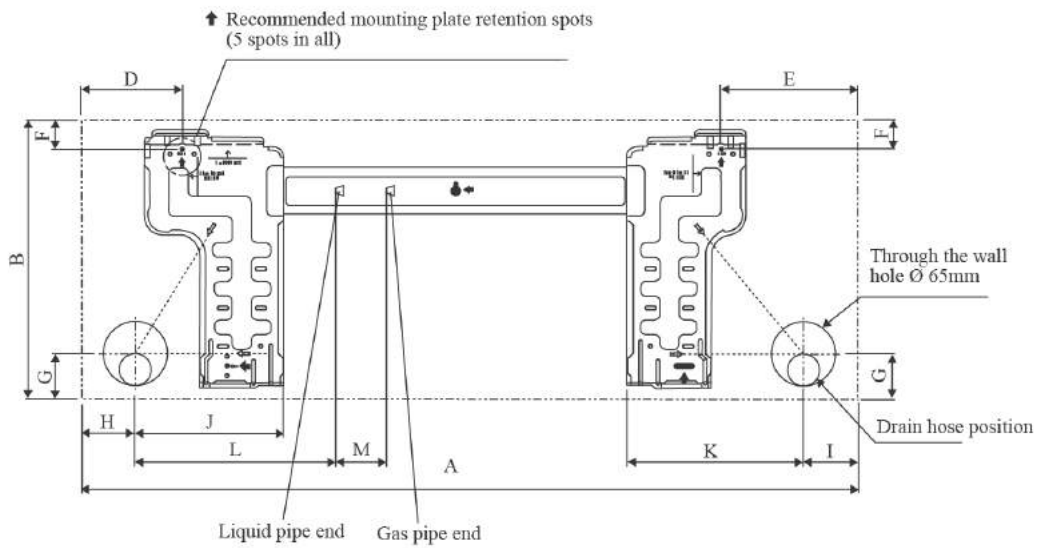

ALTERNATIVE INSTALLATION PLATE 20/25/35

Dimension \ Model	A	B	C	D	E	F	G	H	I	J	K	L	M
20/25/35	800	288	206	104	141	30	46	55	56	153	181	207	52

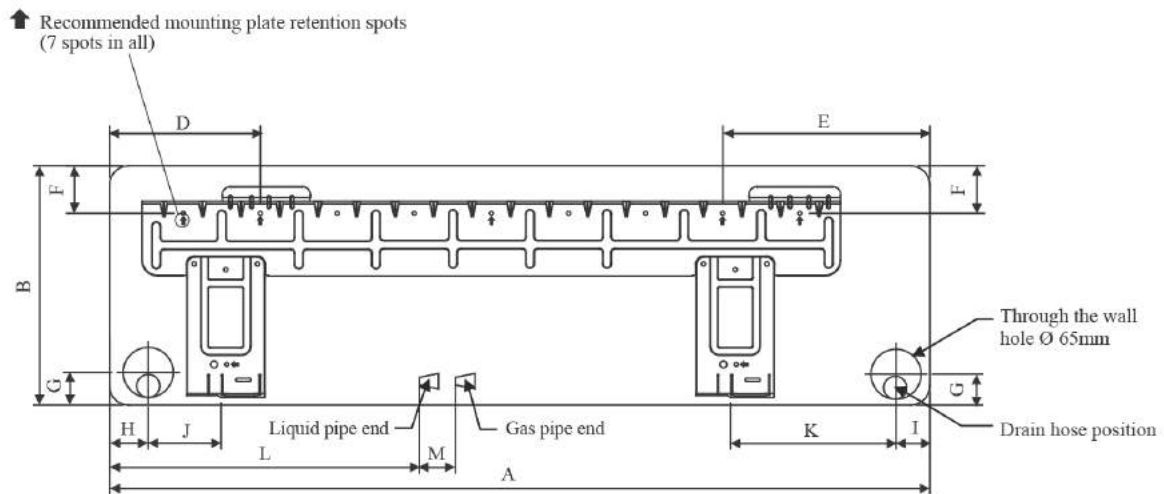

INSTALLATION PLATE 50/60

Dimension \ Model	A	B	C	D	E	F	G	H	I	J	K	L	M
50/60	1065	310	224	190	173	61	40	45	48	91	219	580	45

All dimensions are in mm

**Outdoor Unit (RYN)**

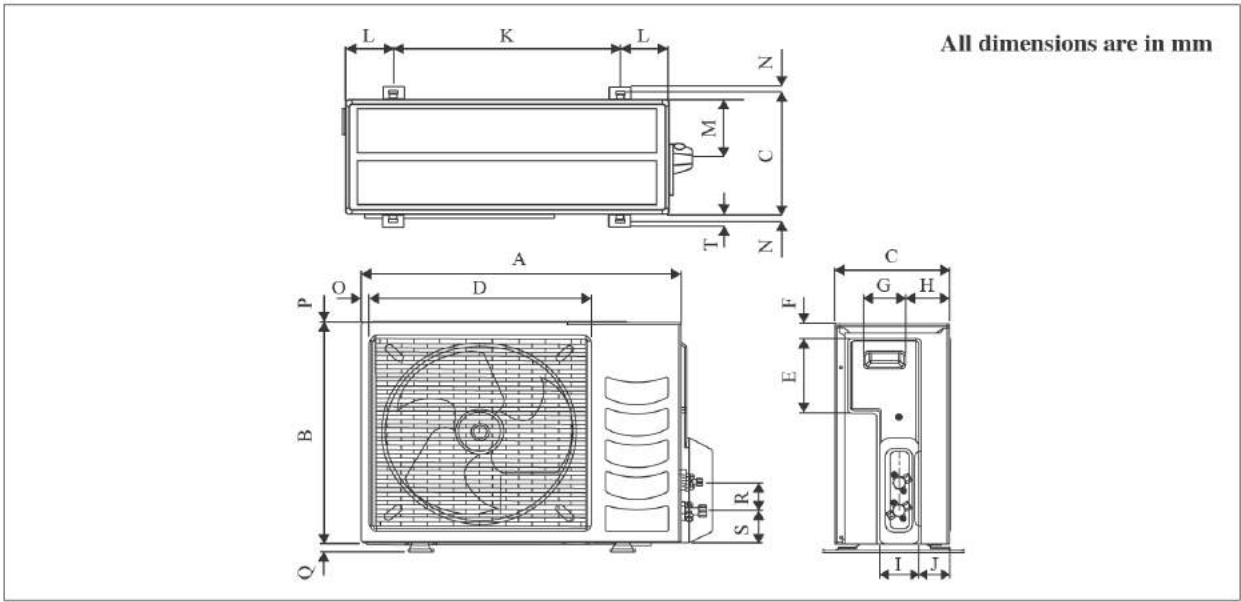

Model \ Dimension	A	B	C	D	E	F	G	H	I	J	K	L	M	N
20/25/35	700	521	250	485	175	36	95	93	86	68	441	130	111	15

Model \ Dimension	O	P	Q	R	S	T
20/25/35	18	3	19	65	80	30

**Outdoor Unit (RYN)**

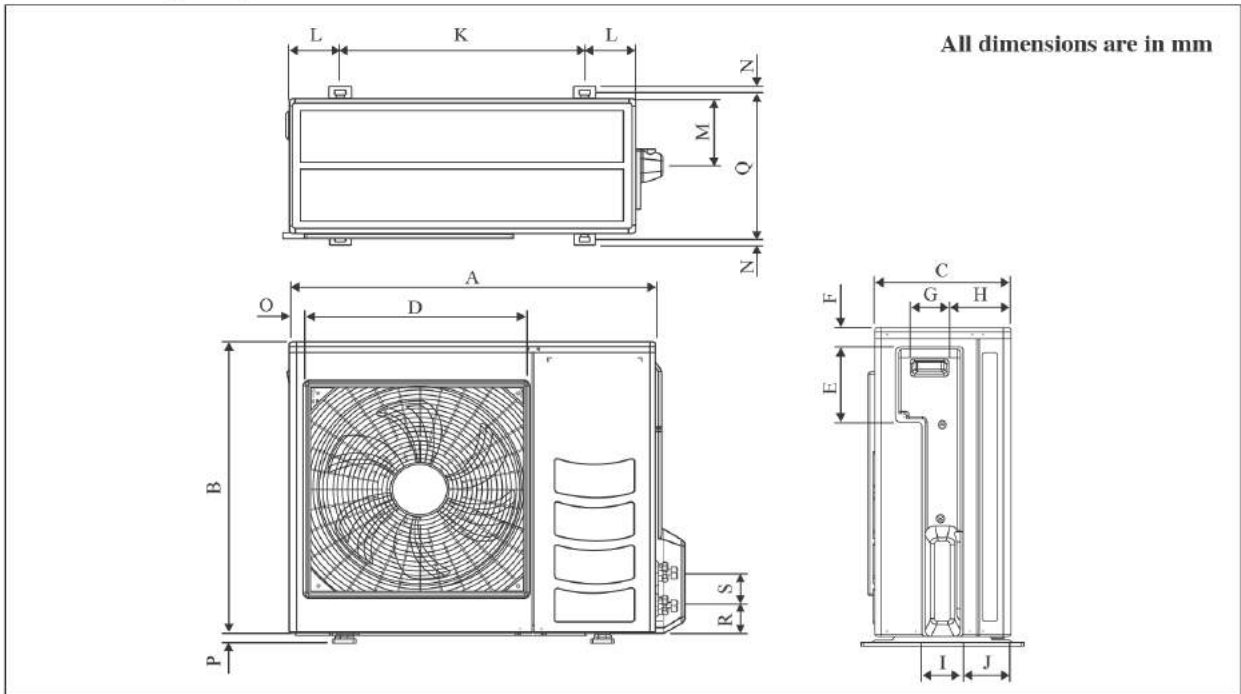

Model \ Dimension	A	B	C	D	E	F	G	H	I	J	K	L	M	N	O
50	855	628	328	520	179	46	93	149	101	113	603	126	164	15	34
60	855	730	328	520	179	46	93	149	101	113	603	126	164	15	34

Model \ Dimension	P	Q	R	S
50	23	362	73	75
60	23	362	73	75



# INSTALLATION MANUAL

This manual provides the procedures of installation to ensure a safe and good standard of operation for the air conditioner unit. Special adjustment may be necessary to suit local requirement.

Before using your air conditioner, please read this instruction manual carefully and keep it for future reference.

This appliance is intended to be used by expert or trained users in shops, in light industry and on farms, or for commercial use by lay persons.

This appliance is not intended for use by persons, including children, with reduced physical, sensory or mental capabilities, or lack of experience and knowledge, unless they have been given supervision or instruction concerning use of the appliance by a person responsible for their safety.

Children should be supervised to ensure that they do not play with the appliance.

## SAFETY PRECAUTIONS

### ⚠ WARNING

- Installation and maintenance should be performed by qualified persons who are familiar with local code and regulation, and experienced with this type of appliance.
- All field wiring must be installed in accordance with the national wiring regulation.
- Ensure that the rated voltage of the unit corresponds to that of the name plate before commencing wiring work according to the wiring diagram.
- The unit must be GROUNDED to prevent possible hazard due to insulation failure.
- All electrical wiring must not touch the water piping or any moving parts of the fan motors.
- Confirm that the unit has been switched OFF before installing or servicing the unit.
- Risk of electric shock, can cause injury or death. Disconnect all remain electric power supplies before servicing.
- DO NOT pull out the power cord when the power is ON. This may cause serious electrical shocks which may result in the fire hazards.
- Keep the indoor and outdoor units, power cable and transmission wiring, at least 1m from TVs and radios, to prevent distorted pictures and static. (Depending on the type and source of the electrical waves, static may be heard even when more than 1m away).

### ⚠ CAUTION

Please take note of the following important points when installing.

- Do not install the unit where leakage of flammable gas may occur.
  - ⊘ If gas leaks and accumulates around the unit, it may cause fire ignition.
- Ensure that drainage piping is connected properly.
  - ⚠ If the drainage piping is not connected properly, it may cause water leakage which will dampen the furniture.
- Do not overcharge the unit.
  - ⊘ This unit is factory pre-charged. Overcharge will cause over-current or damage to the compressor.
- Ensure that the unit's panel is closed after service or installation.
  - ⚠ Unsecured panels will cause the unit to operate noisily.
- Sharp edges and coil surfaces are potential locations which may cause injury hazards. Avoid from being in contact with these places.
- Before turning off the power supply set the remote controller's ON/OFF switch to the "OFF" position to prevent the nuisance tripping of the unit. If this is not done, the unit's fans will start turning automatically when power resumes, posing a hazard to service personnel or the user.
- Do not install the units at or near doorway.
- Do not operate any heating apparatus too close to the air conditioner unit or use in room where mineral oil, oil vapour or oil steam exist, this may cause plastic part to melt or deform as a result of excessive heat or chemical reaction.
- When the unit is used in kitchen, keep flour away from going into suction of the unit.
- This unit is not suitable for factory used where cutting oil mist or iron powder exist or voltage fluctuates greatly.
- Do not install the units at area like hot spring or oil refinery plant where sulphide gas exists.
- Ensure the color of wires of the outdoor unit and the terminal markings are same to the indoors respectively.
- **IMPORTANT : DO NOT INSTALL OR USE THE AIR CONDITIONER UNIT IN A LAUNDRY ROOM.**
- Don't use joined and twisted wires for incoming power supply.
- The equipment is not intended for use in a potentially explosive atmosphere.

## NOTICE

### Disposal requirement

Your air conditioning product is marked with this symbol. This means that electrical and electronic products shall not be mixed with unsorted household waste.

Do not try to dismantle the system yourself: the dismantling of the air conditioning system, treatment of the refrigerant, of oil and of other parts must be done by a qualified installer in accordance with relevant local and national legislation.

Air conditioners must be treated at a specialized treatment facility for re-use, recycling and recovery. By ensuring this product is disposed of correctly, you will help to prevent potential negative consequences for the environment and human health. Please contact the installer or local authority for more information.

Batteries must be removed from the remote controller and disposed of separately in accordance with relevant local and national legislation.



**INSTALLATION DIAGRAM**

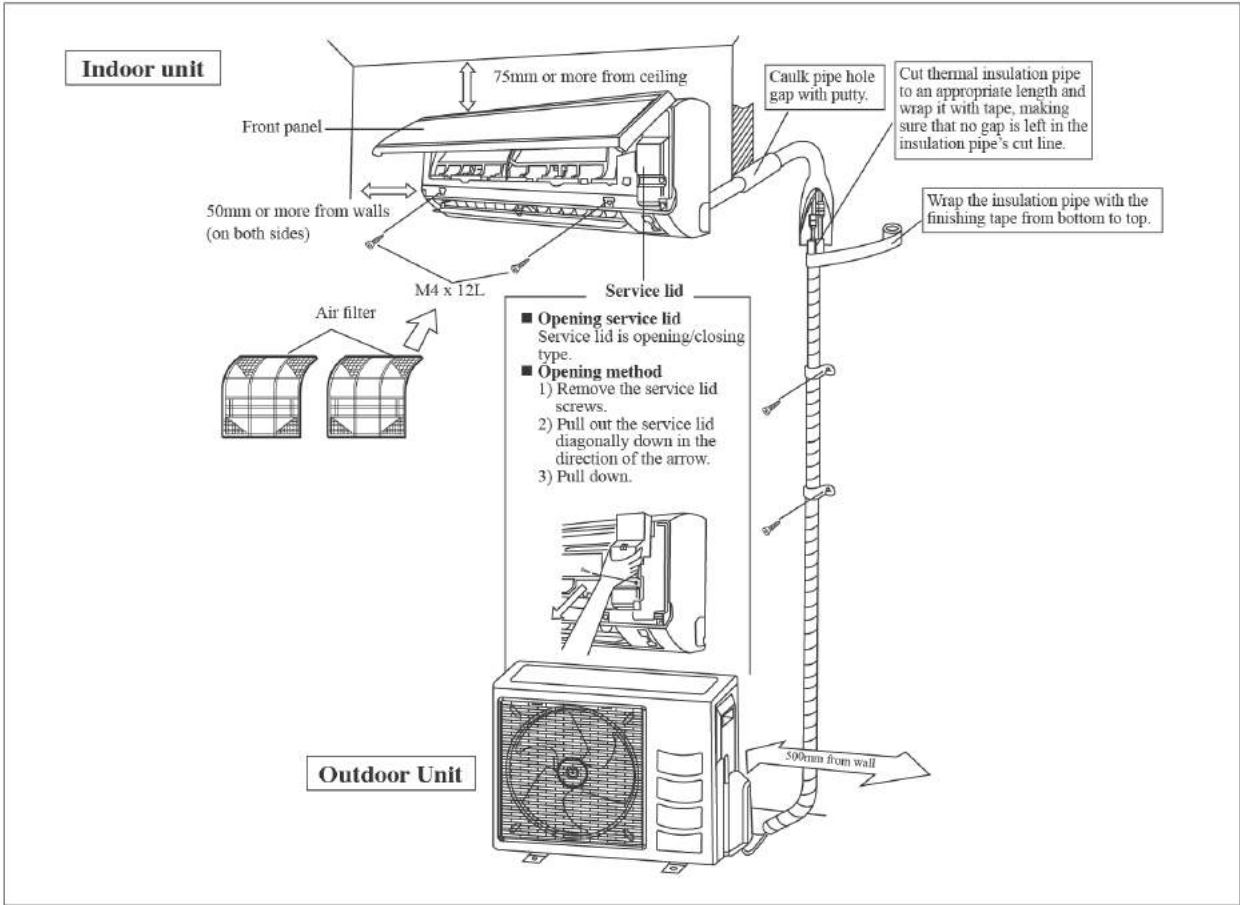

**INSTALLATION OF THE OUTDOOR UNIT**

The outdoor unit must be installed in such a way, so as to prevent short circuit of the hot discharged air or obstruction to the smooth air flow. Please follow the installation clearances shown in the figure. Select the coolest possible place where intake air temperature is not greater than the outside air temperature (please refer operating range).

**Installation clearances**

Dimension	A	B	C	D
Minimum Distance, mm	300	1000	300	500

**Note:** If there is any obstacle higher than half, of the unit's height (H), please allow more space than the figure indicated in the above table.

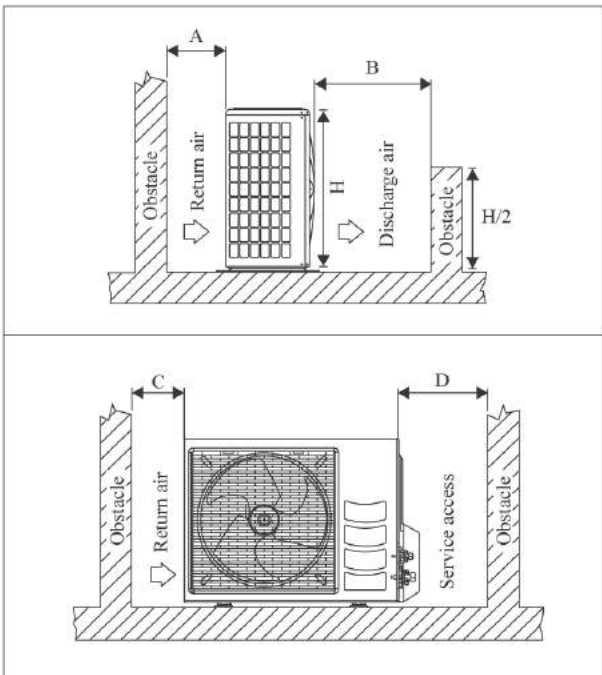

### Condensed Water Disposal Of Outdoor Unit (Heat Pump Unit Only)

- There are 2 holes on the base of Outdoor Unit for condensed water to flow out. Insert the drain elbow to one of the holes.
- To install the drain elbow, first insert one portion of the hook to the base (portion A), then pull the drain elbow in the direction shown by the arrow while inserting the other portion to the base. After installation, check to ensure that the drain elbow clings to base firmly.
- If the unit is installed in a snowy and chilly area, condensed water may freeze in the base. In such case, please remove plug at the bottom of unit to smooth the drainage.

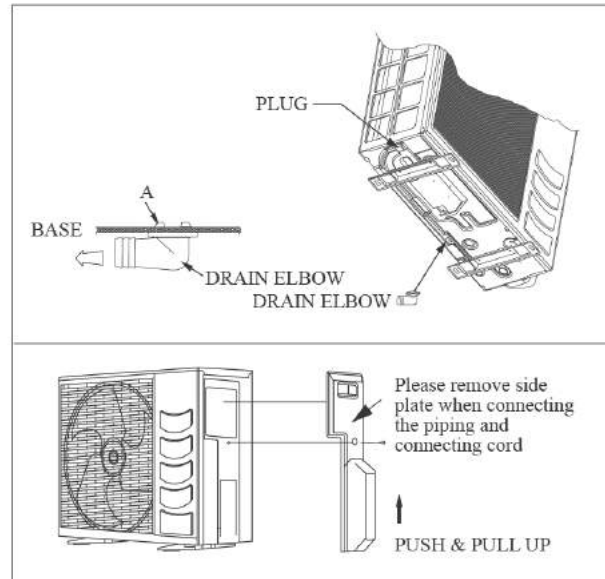

## INSTALLATION OF THE INDOOR UNIT

The indoor unit must be installed in such a way so as to prevent short circuit of the cool discharged air with the hot return air. Please follow the installation clearance shown in the figure. Do not place the indoor unit where there could be direct sunlight shining on it. Also, this location must be suitable for piping and drainage, and be away from doors or windows.

The refrigerant piping can be routed to the unit in a number of ways (left or right from the back of the unit), by using the cut-out holes on the casing of the unit (see figure). Bend the pipes carefully to the required position in order to align it with the holes. For the side and bottom, hold the bottom of the piping and then position it to the required direction (see figure). The condensation drain hose can be taped to the pipes.

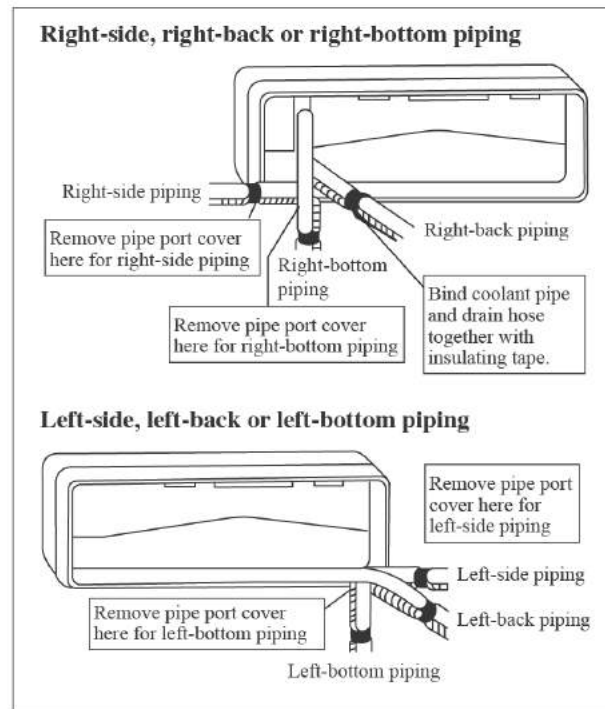
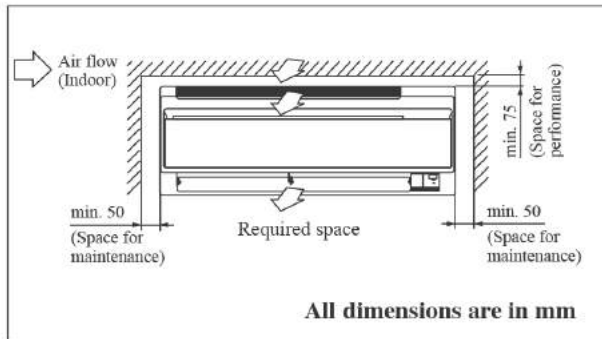



### Mounting Installation Plate

Ensure that the wall is strong enough to withstand the weight of the unit. Otherwise, it is necessary to reinforce the wall with plates, beams or pillars.

Use the level gauge for horizontal mounting, and fix it with 5 suitable screws for FTYN 20/25/35 and 7 suitable screws for FTYN 50/60.

In case the rear piping draws out, drill a hole 65mm in diameter with a cone drill, slightly lower on the outside wall (see figure).

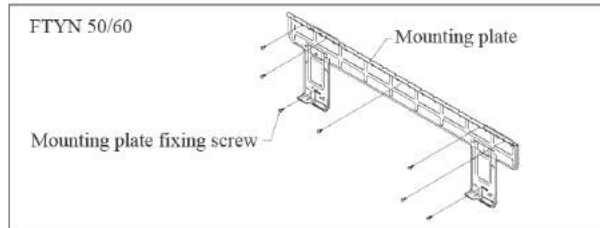
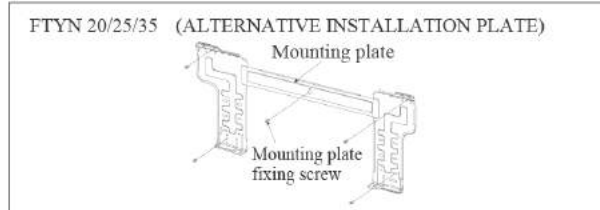
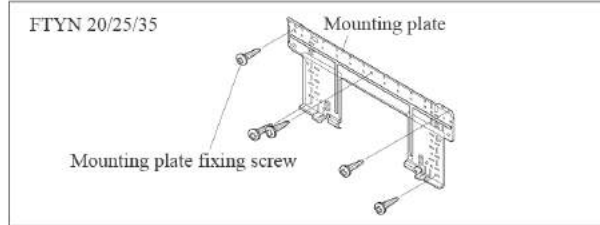

### Recommended Mounting Plate Retention Spots And Dimensions

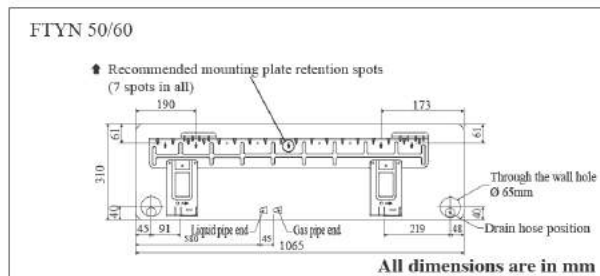
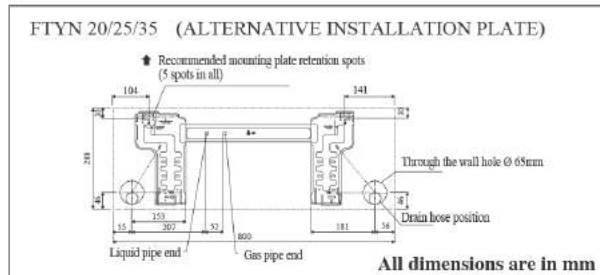
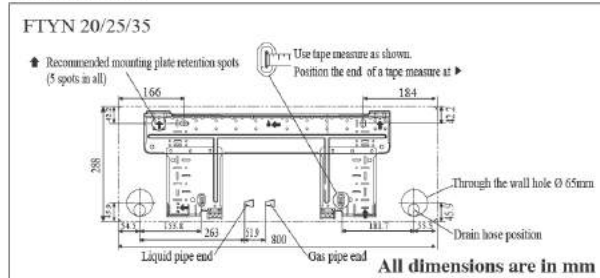

### Hole with cone drill

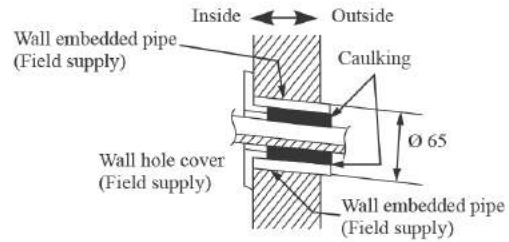

### Mount The Unit Onto The Installation Plate

Hook the indoor unit onto the upper portion of the installation plate (Engage the two hooks at the rear top of the indoor unit with the upper edge of the installation plate). Ensure that the hooks are properly seated on the installation plate by moving it to the left and right.

### How To Attach The Indoor Unit

Hook the claws of the bottom frame to the mounting plate.

### How To Remove The Indoor Unit

Push up the marked area (at the lower part of the front grille) to release the claws.

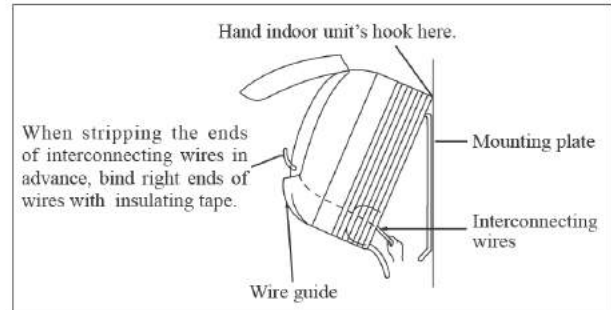
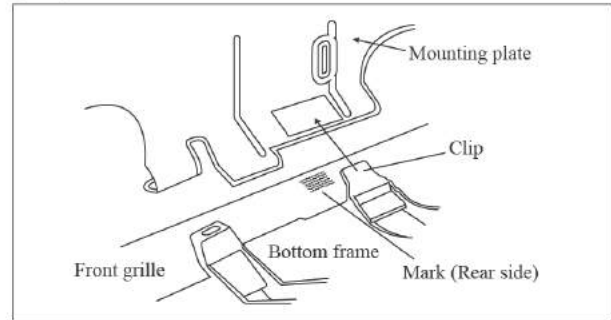

### Water Drainage Piping

The indoor drain pipe must be in a downward gradient for smooth drainage. Avoid situations that are likely to cause water to leak.

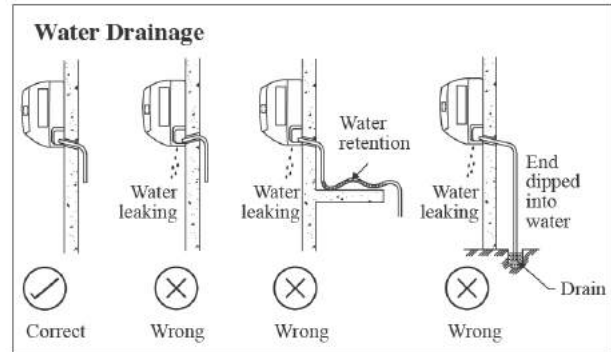

### CAUTION

- Do not install the unit at altitude over 2000m for both indoor & outdoor.

## REFRIGERANT PIPING

### Allowable Piping Length

If the pipe is too long, both the capacity and reliability of the unit will drop. As the number of bends increases, resistance to the flow of refrigerant system increases, thus lowering cooling capacity. As a result, the compressor may become defective. Always choose the shortest path and follow the recommendations as tabulated below:

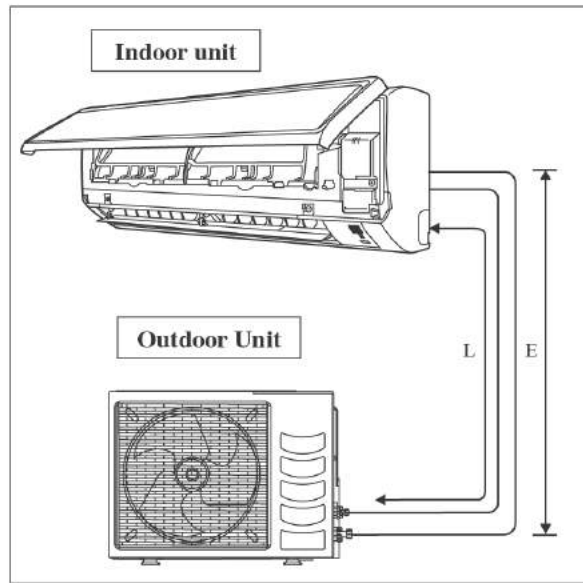



Model (FTYN)	20	25	35	50	60
Min. Allowable Length (L), m	3				
Max. Allowable Length (L), m	12			15	
Max. Allowable Elevation (E), m	5			8	
Gas Pipe Size, mm /(in)	9.52 (3/8")		12.70 (1/2")		15.88 (5/8")
Liquid Pipe Size, mm /(in)	6.35 (1/4")				

\*Be sure to add the proper amount of additional refrigerant. Failure to do so may result in reduced performance.

**Remark:** The refrigerant pre-charged in the outdoor unit is for piping length up to 7.5m.

### Equivalent length for various fitting (meter)

Pipe Size	L joint 	Trap bend 
3/8" (OD9.52mm)	0.18	1.3
1/2" (OD12.7mm)	0.20	1.5
5/8" (OD15.9mm)	0.25	2.0
3/4" (OD19.1mm)	0.35	2.4
7/8" (OD22.2mm)	0.40	3.0
1" (OD25.4mm)	0.45	3.4
1 1/8" (OD28.6mm)	0.50	3.7
1 3/8" (OD34.9mm)	0.60	4.4

Notes:

1. Equivalent piping length is obtained with actual length of gas piping.
2. 90° bend of piping is equivalent to L joint.

Bending must be carefully made so as not to crush the pipe. Use a pipe bender to bend a pipe where possible.

### Piping Works And Flaring Technique

- Do not use contaminated or damaged copper tubing. If any piping, evaporator or condenser had been exposed or had been opened for 15 seconds or more, the system must be vacuumed. Generally do not remove plastic, rubber plugs and brass nuts from the valves, fittings, tubing and coils until it is ready to connect suction or liquid line into valves or fittings.
- If any brazing work is required, ensure that nitrogen gas is passed through coil and joints while the brazing work is being done. This will eliminate soot formation on the inside wall of copper tubings.
- Cut the pipe stages by stages, advancing the blade of pipe cutter slowly. Extra force and a deep cut will cause more distortion of pipe and therefore extra burr. See Figure I.
- Remove burrs from cut edges of the pipes with remover. See Figure II. Hold the pipe on top position and burr remover at lower position to prevent metal chips from entering the pipe. This will avoid unevenness on the flare faces which will cause gas leak.
- Insert the flare nuts, mounted on the connection parts of both the indoor unit and outdoor unit, into the copper pipes.
- The exact length of pipe protruding from the top surface of the swaging block is determined by the flaring tool. See Figure III.
- Fix the pipe firmly on the swaging block. Match the centers of both the swaging block and the flaring punch, then tighten the flaring punch fully.

### Piping Connection To The Units

- Align the center of the piping and tighten the flare nut sufficiently with fingers. See Figure IV.
- Finally, tighten the flare nut with torque wrench until the wrench clicks.
- When tightening the flare nut with the torque wrench, ensure that the tightening direction follows the arrow indicated on the wrench.
- The refrigerant pipe connection are insulated by closed cell polyurethane.

Pipe Size (mm/in)	Torque (Nm/ft-lb)
6.35 (1/4")	18 (13.3)
9.52 (3/8")	42 (31.0)
12.70 (1/2")	55 (40.6)
15.88 (5/8")	65 (48.0)
19.05 (3/4")	78 (57.6)

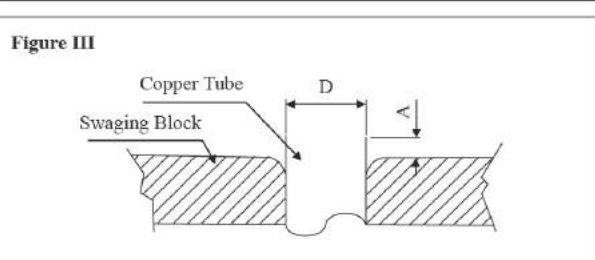
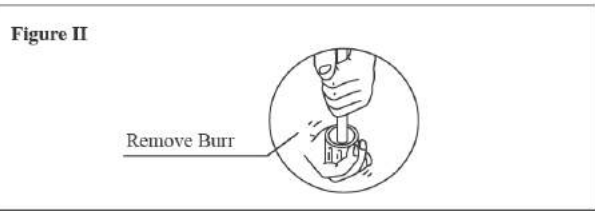
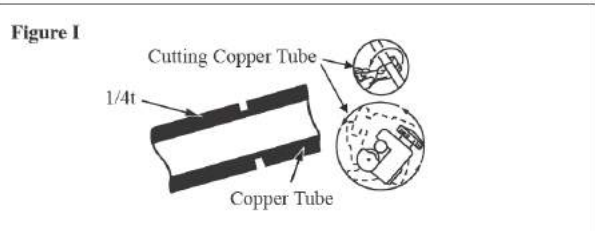

Ø Tube, D		A (mm)	
Inch	mm	Imperial (Wing-nut Type)	Rigid (Clutch Type)
1/4"	6.35	1.3	0.7
3/8"	9.52	1.6	1.0
1/2"	12.70	1.9	1.3
5/8"	15.88	2.2	1.7
3/4"	19.05	2.5	2.0

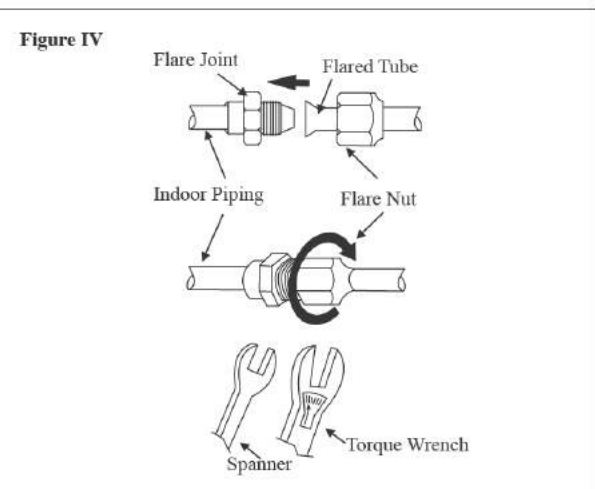



## ELECTRICAL WIRING CONNECTION

- IMPORTANT :** \* The figures shown in the table are for information purpose only. They should be checked and selected to comply with the local/national codes of regulations. This is also subject to the type of installation and conductors used.
- \*\* The appropriate voltage range should be checked with label data on the unit.

### Heat Pump Unit (single phase)

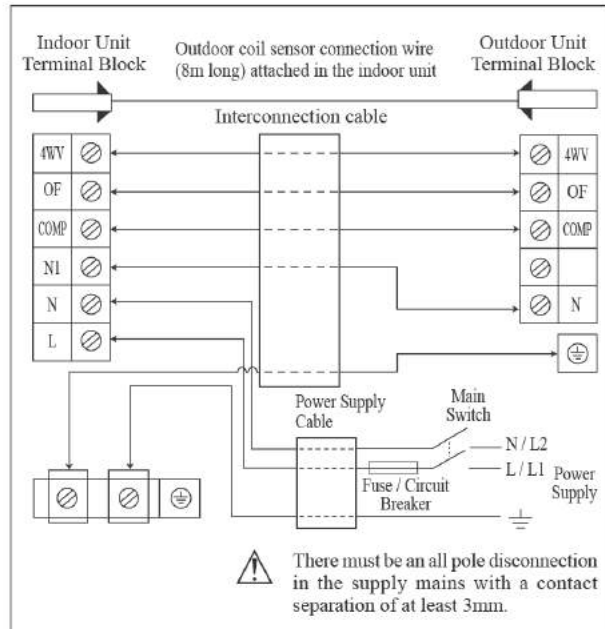

Model	Indoor (FTYN)	20	25	35	50	60
	Outdoor (RYN)	20	25	35	50	60
Voltage range**	220-240V/~/50Hz + ⊕					
Power supply cable size*	mm <sup>2</sup>	1.5			2.5	
Number of conductors		3			3	
Interconnection cable size*	mm <sup>2</sup>	1.5			2.5	
Number of conductors		5			5	
Recommended fuse /circuit breaker rating	A	15			20	

- All wires must be firmly connected.
- All wires must not touch the refrigerant piping, compressor or any moving parts of the fan motor.
- The connecting wires between the indoor unit and the outdoor unit must be clamped on the wire clamps.
- The power supply cord must be equivalent to H07RN-F which is the minimum requirement.
- Make sure no external pressure is applied to the terminal connectors and wires.
- Make sure all the covers are properly fixed to avoid any gap.
- Use round crimp-style terminal for connecting wires to the power supply terminal block. Connect the wires by matching to the indication on terminal block. (Refer to the wiring diagram attached on the unit).

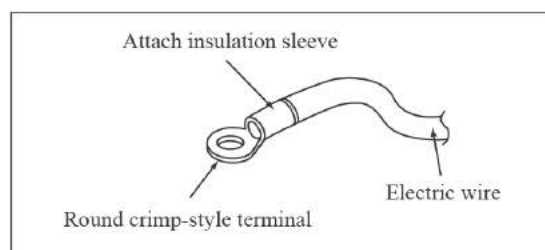

- Used the correct screwdriver for terminal screws tightening. Unsuitable screwdrivers can damage the screw head.
- Over tightening can damage the terminal screws.
- Do not connect wire of different gauge to same terminal.
- Keep wiring in an orderly manner. Prevent the wiring from obstructing other parts and the terminal box cover.

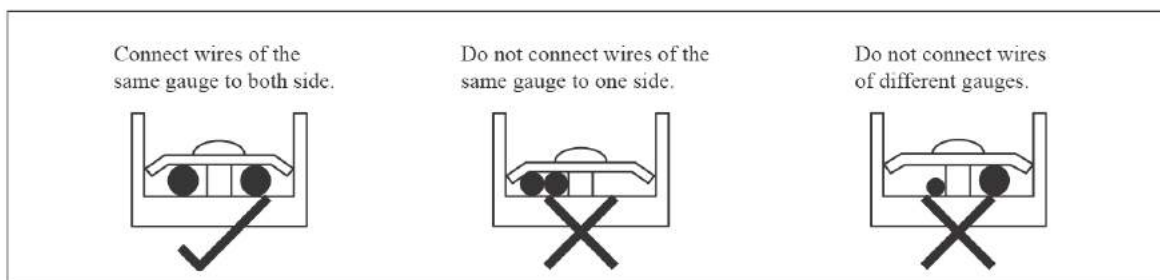

## SPECIAL PRECAUTIONS WHEN DEALING WITH R410A UNIT

R410A is a new HFC refrigerant which does not damage the ozone layer. The working pressure of this new refrigerant is 1.6 times higher than conventional refrigerant (R22), thus proper installation/servicing is essential.

- Never use refrigerant other than R410A in an air conditioner which is designed to operate with R410A.
- POE or PVE oil is used as lubricant for R410A compressor, which is different from the mineral oil used for R22 compressor. During installation or servicing, extra precaution must be taken not to expose the R410A system too long to moist air. Residual POE or PVE oil in the piping and components can absorb moisture from the air.
- To prevent mischarging, the diameter of the service port on the flare valve is different from that of R22.

- Use tools and materials exclusively for refrigerant R410A. Tools exclusively for R410A are manifold valve, charging hose, pressure gauge, gas leak detector, flare tools, torque wrench, vacuum pump and refrigerant cylinder.
- As an R410A air conditioner incurs higher pressure than R22 units, it is essential to choose the copper pipes correctly.
- If the refrigerant gas leakage occurs during installation/servicing, be sure to ventilate fully. If the refrigerant gas comes into contact with fire, a poisonous gas may occur.
- When installing or removing an air conditioner, do not allow air or moisture to remain in the refrigerant cycle.

## VACUUMING AND CHARGING

Vacuuming is necessary to eliminate all moisture and air from the system.

### Vacuuming The Piping And The Indoor Unit

Except for the outdoor unit which is pre-charged with refrigerant, the indoor unit and the refrigerant connection pipes must be air-purged because the air containing moisture that remains in the refrigerant cycle may cause malfunction of the compressor.

- Remove the caps from the valve and the service port.
- Connect the center of the charging gauge to the vacuum pump.
- Connect the charging gauge to the service port of the 3-way valve.
- Start the vacuum pump. Evacuate for approximately 30 minutes. The evacuation time varies with different vacuum pump capacity. Confirm that the charging gauge needle has moved towards -760mmHg.

#### Caution

- If the gauge needle does not move to -760mmHg, be sure to check for leakage at flare type connection of the indoor and outdoor unit and repair the leak before proceeding to the next step.
- Close the valve of the charging gauge and stop the vacuum pump.
- On the outdoor unit, open the suction valve (3 way) and liquid valve (2 way) (in anti-clockwise direction) with 4mm key for hexagon sanded screw.

### Charge Operation

This operation must be done by using a gas cylinder and a precise weighing machine. The additional charge is topped-up into the outdoor unit using the suction valve via the service port.

- Remove the service port cap.
- Connect the low pressure side of the charging gauge to the suction service port center of the cylinder tank and close the high pressure side of the gauge. Purge the air from the service hose.
- Start the air conditioner unit.
- Open the gas cylinder and low pressure charging valve.
- When the required refrigerant quantity is pumped into the unit, close the low pressure side and the gas cylinder valve.
- Disconnect the service hose from service port. Put back the service port cap.

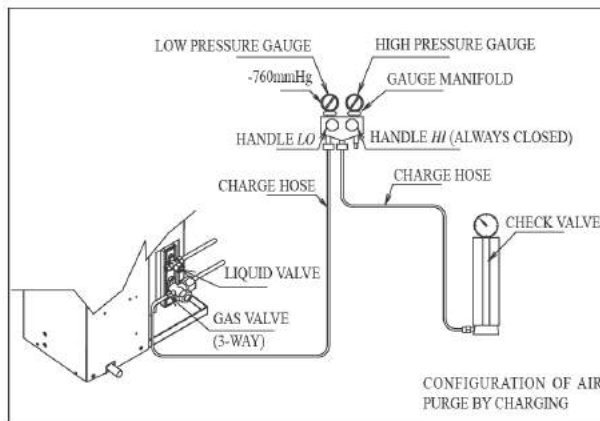
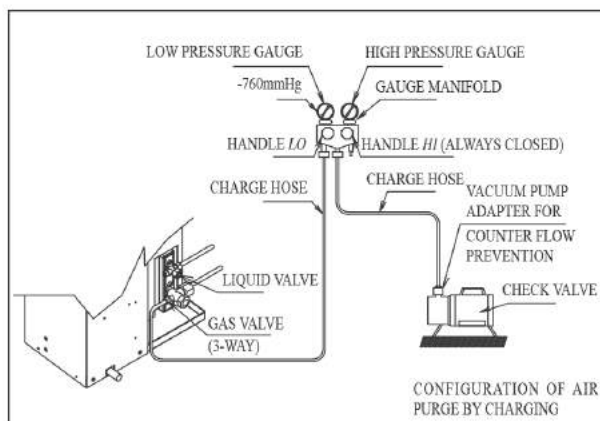
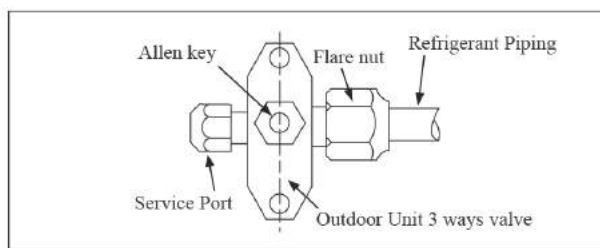



## ADDITIONAL CHARGE

The refrigerant is pre-charged in the outdoor unit. If the piping length is less than 7.5m, then additional charge after vacuuming is not necessary. If the piping length is more than 7.5m, then use the additional charge value as indicated in the table.

**Additional refrigerant charge [g] per additional 1m length as tabulated.**

<b>Indoor (FTYN)</b>	<b>20</b>	<b>25</b>	<b>35</b>	<b>50</b>	<b>60</b>
<b>Outdoor (RYN)</b>	<b>20</b>	<b>25</b>	<b>35</b>	<b>50</b>	<b>60</b>
<b>Additional charge [g/m]</b>	16	16	16	16	16

### Example:

FTYN25 & RYN25 with 12m piping length, additional piping length is 4.5m. Thus,  
 Additional charge = 4.5[m] x 16[g/m]  
 = 72.0[g]

## INDICATOR LIGHTS

### IR Signal Receiver

When an infrared remote control operating signal has been transmitted, the signal receiver on the indoor unit will respond as below to confirm acceptance of the signal transmission.

<b>ON to OFF</b>	1 Long Beep
<b>OFF to ON</b>	2 Short Beep
<b>Pump down/Cool force on</b>	
<b>Others</b>	1 Short Beep

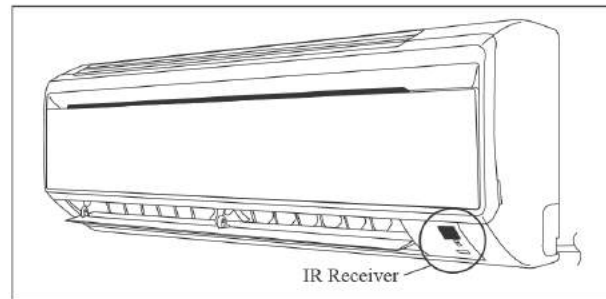

### Heat Pump Unit

The table shows the LED indicator lights for the air conditioner unit under normal operation and fault conditions.







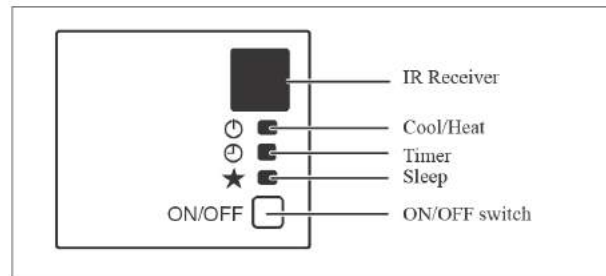



















The LED indicator lights are located at the right bottom of the air conditioner unit.

The heat pump units are equipped with an “auto” mode sensor whereby it will provide reasonable room temperature by switching automatically to either “cool” or “heat” mode according to the temperature set by the user.

### LED Indicator Lights for Heat Pump Unit



## LED Indicator Lights: Normal Operation And Fault Conditions For Heat Pump Unit

	 COOL/HEAT (GREEN/RED)		Normal Operation/Fault Indication	Action	Error Code
	 Green		Cool mode	-	-
	 Red		Heat mode	-	-
	 Red		Auto mode in Heating operation	-	-
	 Green		Auto mode in Cooling operation	-	-
			Timer on	-	-
			Sleep mode on	-	-
			Fan mode on	-	-
			Dry mode on	-	-
	 1 time		Room air sensor contact Loose/Short	Call your dealer	Blink E1
	 3 times		Outdoor coil sensor open	Call your dealer	Blink E3
	 2 times		Indoor coil sensor open	Call your dealer	Blink E2
		 1 time	Compressor overload/ Indoor coil sensor short/ outdoor coil sensor short	Call your dealer	Blink E4
	 Red		Defrost operation	-	-
		 3 times	Low Refrigerant Charge/Gas Leak/Outdoor Abnormal	Call your dealer	Blink E5
		 6 times	Hardware error (tact switch pin short)	Call your dealer	Blink E8
	 4 times		No feedback from indoor fan	Call your dealer	Blink E9

○ ON

○/● ON or OFF

● Blinking

## AIR CONDITIONER UNIT OPERATION

### Dry Mode

- When the air humidity is high, the unit can operate in dry mode. Press <MODE> button and choose <DRY>.
- If the room temperature is 2°C/3.6°F higher than the set temperature, the air conditioner will operate under cooling mode until it reaches within the 2°C/3.6°F range of difference compared to the set temperature before it converts to dry mode.
- If the room temperature is within the 2°C/3.6°F range of difference compared to the set temperature, it will directly operate under dry mode.
- The unit will operate at LOW speed under dry mode.

### Heat Mode (for heat pump unit only)

- When the unit is switched on from cold start or defrosting cycle, the indoor fan will start to operate only after the coil reaches the desired temperature.
- When the set temperature is achieved, the indoor fan will operate until the coil cannot provide anymore additional heat.

### Air Flow Control

- For more effective air circulation, you can manually adjust the air discharge grille to the left or right.
- During cool mode operation and dry mode operation, do not direct the air discharge louver downwards for too long. If operating continues in this way, condensation may occur on the louver, thus resulting in drippings.

### Overheating Protection (for heat pump unit only)

- In case the internal and/or the external temperature is too high, or that the filter is dirty and clogged up, the refrigerant may be overheated. The compressor will cut out when the condensing temperature reaches 62°C/143.6°F.

### Frost Prevention

- When the air filter is dirty, the evaporating temperature will decrease and eventually cause frosting.
- If the evaporating temperature reaches -1°C/33.8°F, the unit will trip.

### Fan Speed And Rated Cooling Capacity

- The rated cooling capacity is provided at the HIGH fan speed.
- The cooling capacity is lower when the unit is operating at MEDIUM and LOW fan speed.

### Notes On Flaps And Louvers Angles

- When “SWING button” is selected, the flaps swinging range depends on the operation mode. (See the figure.)

### ATTENTION

- Always use a remote controller to adjust the flaps angle. If you attempt to move it forcibly with hand when it is swinging, the mechanism may be broken.
- Be careful when adjusting the louvers. Inside the air outlet, a fan is rotating at a high speed.

#### In COOL, DRY and FAN mode

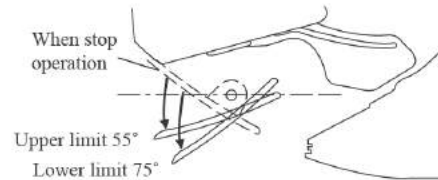

#### In HEAT mode

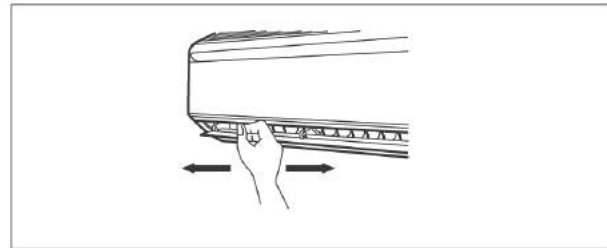
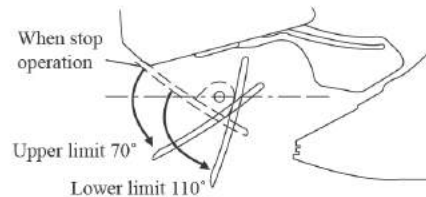

## OPERATING RANGE

### HEATING

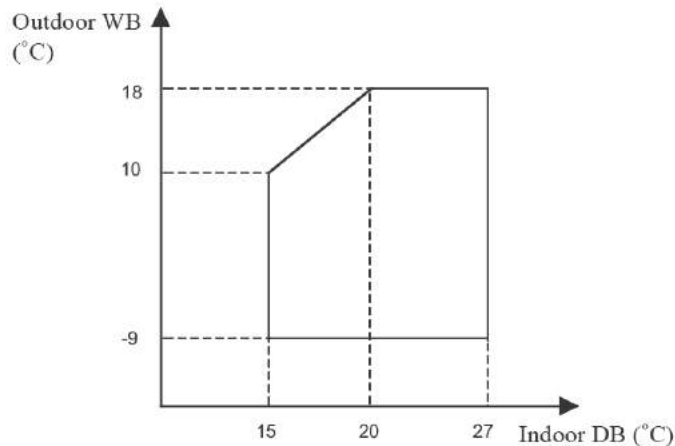

DB: Dry bulb  
WB: Wet bulb

## AIR FILTER

### 1. Open the front panel.

- Hold the panel at the recesses on the main unit (2 recesses on right and left sides) and lift it until it stops.

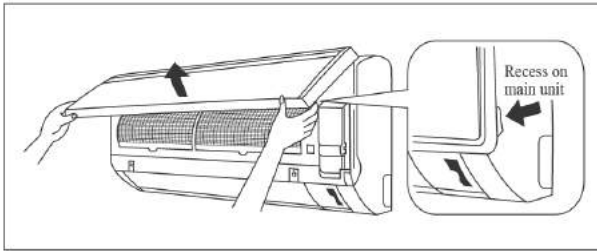

### 2. Pull out the air filters.

- Push a little upwards the tab at the center of each air filter, then pull it down.

### 3. Clean or replace each filter

- When shaking off remaining water, do not wring the filter.

### 4. Set the air filter as they were and close the front panel.

- Insert claws of the filters into slots of the front panel. Close the front panel slowly and push the panel at the 3 points. (1 on each side and 1 in the middle.)
- The air filter and Bio filter with bacteriostatic, virustatic functions have a symmetrical form in the horizontal direction.

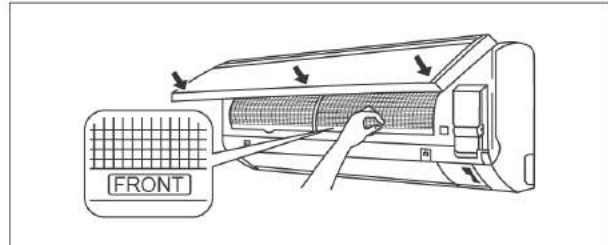

## ⚠ CAUTION

- **Storage, handling and disposal methods.**
  - The lifetime of this Bio Filter is about a year after opening.
  - In case you do not use this Bio Filter right away, please don't place the Bio Filter in any place where it will be subjected to direct sunlight, high temperatures and/or high humidity.
  - There can be slight differences between Bio Filter color because of the manufacturing reasons, there is no effect on the unit performance.
  - Please open this bag right before you use it. Bio Filter should remain unopened and sealed in its packaging until right before usage. (It may cause performance deterioration or quality change.)
  - To avoid danger of suffocation and any unexpected accident, please dispose the plastic bag immediately after you remove the Bio Filter. Keep out of reach of babies and children.
  - If you keep this Bio Filter for a long time, please keep it unopened and store in a cool place avoiding direct sunlight.
  - Please dispose the old Bio Filter as nonflammable garbage after use.
- **Operation with dirty Filters:**
  - (1) cannot deodorize the air.
  - (2) cannot clean the air.
  - (3) results in poor heating or cooling.
  - (4) may cause odour.
- To order Bio Filter, contact the service shop where you bought the air conditioner.



## SERVICE AND MAINTENANCE

Service Parts	Maintenance Procedures	Period
<b>Indoor Air Filter</b>	<ol style="list-style-type: none"> <li>1. Remove any dust adhered on the filter by using a vacuum cleaner or wash in lukewarm water (below 40°C) with neutral cleaning detergent.</li> <li>2. Rinse well and dry the filter before placing it back onto the unit.</li> <li>3. Do not use gasoline, volatile substances or chemical to clean the filter.</li> </ol>	At least once every 2 weeks. More frequently when necessary.
<b>Indoor Unit</b>	<ol style="list-style-type: none"> <li>1. Clean any dirt or dust on the grille or panel by wiping it using soft cloth soaked in lukewarm water (below 40°C) with neutral detergent solution.</li> <li>2. Do not use gasoline, volatile substances or chemical to clean the indoor unit.</li> </ol>	At least once every 2 weeks. More frequently when necessary.
<b>Indoor Fan</b>	<ol style="list-style-type: none"> <li>1. Check for any abnormal noise.</li> </ol>	When necessary.

### ⚠ CAUTION

- Avoid direct contact of any coil treatment cleaners on plastic part. This may cause plastic part to deform as a result of chemical reaction.

#### 1. Open the front panel.

- Hold the panel at the recesses on the main unit (2 recesses on right and left sides) and lift it until it stops.

#### 2. Remove the front panel.

- While lifting the front panel further, slide it to the right and pull it to the front side. The left rotating shaft is detached. Slide the right rotating shaft to the left and pull it to the front side to remove it.

#### 3. Attach the front panel.

- Align the right and left rotating shafts of the front panel with the grooves and push them all the way in.
- Gently close the front panel. (Push both ends and the center on the front panel.)

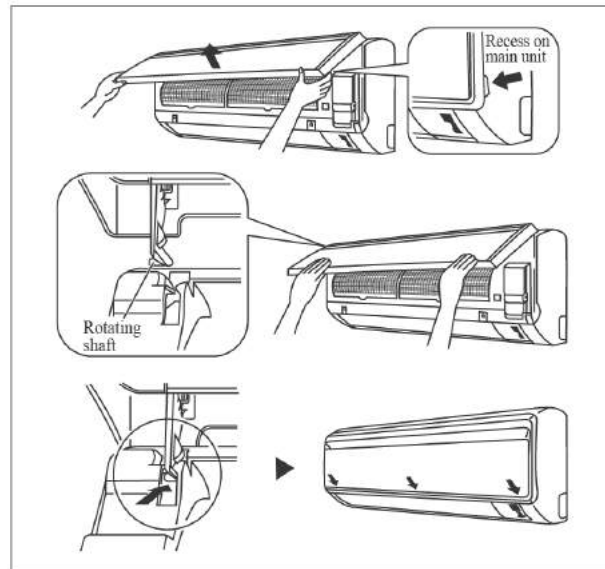



### ⚠ CAUTION

- Don't touch the metal parts of the indoor unit. It may cause an injury.
- When removing or attaching the front panel, support the panel securely with hand to prevent it from falling.
- For cleansing, do not use hot water above 40°C, benzene, gasoline, thinner, nor other volatile oils, polishing compound, scrubbing brushes, nor other hand stuff.
- After cleaning, make sure that the front panel is securely fixed.



## When The Unit Is Not To Be Used For An Extended Long Period Of Time

<p>Operate the unit for 2 hours with the following setting.</p> <p>Operating mode : cool Temperature : 30°C/86°F</p>		<p>Remove the power plug. If you are using an independent electric circuit for your unit, cut off the circuit. Remove the batteries in the remote control.</p>	
--	---	--	---

### TROUBLESHOOTING

**For any enquiries on spare part please contact your authorized dealer. When any malfunction of the air conditioner unit is noted, immediately switch off the power supply to the unit. Check the following fault conditions and causes for some simple troubleshooting tips.**

Fault	Causes / Action
1. The compressor does not operate 3 minutes after the air conditioner unit is started.	– Protection against frequent starting. Wait for 3 to 4 minutes for the compressor to start operating.
2. The air conditioner unit does not operate.	<ul style="list-style-type: none"> <li>– Power failure, or the fuse needs to be replaced.</li> <li>– The power plug is disconnected.</li> <li>– It is possible that your delay timer has been set incorrectly.</li> <li>– If the fault persist after all these verifications, please contact the air conditioner unit installer.</li> </ul>
3. The air flow is too low.	<ul style="list-style-type: none"> <li>– The air filter is dirty.</li> <li>– The doors or windows are open.</li> <li>– The air suction and discharge are clogged.</li> <li>– The regulated temperature is not high enough.</li> </ul>
4. Discharge air flow has bad odour.	– Odours may be caused by cigarettes, smoke particles, perfume etc. which might have adhered onto the coil.
5. Condensation on the front air grille of the indoor unit.	<ul style="list-style-type: none"> <li>– This is caused by air humidity after an extended long period of operation.</li> <li>– The set temperature is too low, increase the temperature setting and operate the unit at high fan speed.</li> </ul>
6. Water flowing out from the air conditioner unit.	– Switch off unit and call dealer.

**If the fault persists, please call your local dealer / serviceman.**

- In the event that there is any conflict in the interpretation of this manual and any translation of the same in any language, the English version of this manual shall prevail.
- The manufacturer reserves the right to revise any of the specification and design contain herein at any time without prior notification.
- En cas de désaccord sur l'interprétation de ce manuel ou une de ses traductions, la version anglaise fera autorité.
- Le fabriquant se réserve le droit de modifier à tout moment et sans préavis la conception et les caractéristiques techniques des appareils présentés dans ce manuel.
- Im Falle einer widersprüchlichen Auslegung der vorliegenden Anleitung bzw. einer ihrer Übersetzungen gilt die Ausführung in Englisch.
- Änderungen von Design und technischen Merkmalen der in dieser Anleitung beschriebenen Geräte bleiben dem Hersteller jederzeit vorbehalten.
- Nel caso ci fossero conflitti nell'interpretazione di questo manuale o delle sue stesse traduzioni in altre lingue, la versione in lingua inglese prevale.
- Il fabbricante mantiene il diritto di cambiare qualsiasi specificazione e disegno contenuti qui senza precedente notifica.
- En caso de conflicto en la interpretación de este manual, y en su traducción a cualquier idioma, prevalecerá la versión inglesa.
- El fabricante se reserva el derecho a modificar cualquiera de las especificaciones y diseños contenidos en el presente manual en cualquier momento y sin notificación previa.
- В случае противоречия перевода данного руководства с другими переводами одного и того же текста, английский вариант рассматривается как приоритетный.
- Завод-изготовитель оставляет за собой право изменять характеристики и конструкцию в любое время без предварительного уведомления.
- Bu kılavuzun anlaşılmasında bir çatışma olduğunda ve farklı dillerdeki tercümelemler farklılık gösterdiğinde, bu kılavuzun İngilizce sürümü üstün tutulacaktır.
- Üretici burada bulunan herhangi teknik özellikleri ve tasarımları herhangi bir zamanda ve önceden haber vermeden değiştirme hakkını saklı tutar.

---

**DAIKIN EUROPE N.V.**

Zandvoordestraat 300, B-8400 Oostende,  
Belgium

**DAIKIN MIDDLE EAST AND AFRICA FZE**

P.O.Box 18674, Jebel Ali Free Zone, Dubai-UAE  
Email: [info@daikinmea.com](mailto:info@daikinmea.com)  
Web: [www.daikinmea.com](http://www.daikinmea.com)

Importer for Turkey

**DAIKIN ISITMA ve SOĞUTMA SİSTEMLERİ SAN TİC A.Ş.**

Allianz Plaza-Kucukbakkalkoy Mah.Kayısdagi Cad.No:1 34750  
Atasehir-ISTANBUL / TÜRKİYE

**DAIKIN INDUSTRIES, LTD.**

Head office:  
Umeda Center Bldg., 2-4-12, Nakazaki-Nishi,  
Kita-ku, Osaka, 530-8323 Japan

Tokyo office:  
JR Shinagawa East Bldg., 2-18-1, Konan,  
Minato-ku, Tokyo, 108-0075 Japan  
<http://www.daikin.com/global/>

- اذا حدث اي تعارض في تفسير هذا الكتيب واي اختلاف في الترجمة نفسها بأية لغة كانت. تكون النسخة الانكليزية هي السائدة.
- يحتفظ المصنع بحق تعديل التصميم واية مواصفات موجودة هنا في اي وقت من دون إشعار مسبق.

---

**DAIKIN INDUSTRIES, LTD.**

Head office:  
Umeda Center Bldg., 2-4-12, Nakazaki-Nishi,  
Kita-ku, Osaka, 530-8323 Japan

Tokyo office:  
JR Shinagawa East Bldg., 2-18-1, Konan,  
Minato-ku, Tokyo, 108-0075 Japan  
<http://www.daikin.com/global/>

**DAIKIN EUROPE N.V.**

Zandvoordestraat 300, B-8400 Oostende,  
Belgium

**DAIKIN MIDDLE EAST AND AFRICA FZE**

P.O.Box 18674, Jebel Ali Free Zone, Dubai-UAE  
Email: [info@daikinmea.com](mailto:info@daikinmea.com)  
Web: [www.daikinmea.com](http://www.daikinmea.com)

Importer for Turkey

**DAIKIN ISITMA ve SOĞUTMA SISTEMLERİ SAN TİC A.Ş.**

Allianz Plaza-Kucukbakkalkoy Mah.Kayısdagi Cad.No:1 34750  
Atasehir-ISTANBUL / TURKIYE